



TV - UHF

medium
power

Version
01.02

August
2007

Family of UHF Transmitters R&S® NH/NV 8200

Air-cooled transmitters for analog and digital TV (DVB-T/-H, ATSC)

- ◆ 500 W to 2 kW output power for analog TV
- ◆ 200 W to 1.2 kW output power for DVB-T/-H
- ◆ 300 W to 1.2 kW output power for ATSC
- ◆ Frequency range 470 MHz to 862 MHz
- ◆ Multistandard exciter
- ◆ Easy software upgrade to DVB-H
- ◆ Color display
- ◆ Multilingual menus
- ◆ High redundancy
- ◆ Various standby configurations
- ◆ Flexible air ducting
- ◆ Compact 19" rack with integrated fans
- ◆ Easy servicing due to modular design and plug-ins
- ◆ In-depth diagnostics through new bus system
- ◆ Power amplifiers based on LDMOS technology
- ◆ Transmitter remote control and monitoring via SNMP and/or HTTP interface



ROHDE & SCHWARZ

Design concept at a glance

Standardized design for analog and digital TV

The new air-cooled R&S®NH/NV 8200 family of transmitters has been designed for the analog TV standards (B/G, D/K, M/N, I), color coding standards (SECAM, PAL, NTSC) and sound coding standards (FM mono, dual-sound/stereo IRT and NICAM) as well as for the digital TV standards (DVB-T/-H, ATSC). LDMOS transistor-based amplifiers ensure high output power while requiring only minimum space. All components are fully broadband from 470 MHz to 862 MHz (UHF bands IV/V) for both the analog and digital standards. For analog TV (combined), available output power ranges from 500 W to 2 kW, for digital TV from 200 W to 1.2 kW (DVB-T/-H) and 300 W to 1.2 kW (ATSC).

The transmitters include the following components:

- ◆ Exciter
- ◆ Power amplifier(s)
- ◆ Transmitter control unit
- ◆ Transmitter rack with cooling system

The new family of UHF Transmitters R&S®NH/NV 8200 relies on a design concept common to all Rohde & Schwarz sound and TV transmitters of the Nx 8000 family. This means that the transmitter control unit and the bus system for internal and external communication are identical throughout.

TV Exciter R&S®Sx800

Using state-of-the-art technology, the new multistandard TV Exciter R&S®Sx800 can be accommodated in a housing of only one height unit. It performs full signal processing from the video/audio input signal (analog TV) or the transport stream (digital TV) to the standard-conforming RF output signal. Its flexible concept ensures high safety of investment.

The new TV Exciter R&S®Sx800 contains the following main modules:

- ◆ Input interface
- ◆ Mainboard
- ◆ RF interface

Input interface

For the analog TV standards, the input interface converts the analog video and audio input signals to digital signals for further processing. Optionally, the input interface encodes and modulates the NICAM subcarrier. NICAM signal processing supports the analog sound input, NICAM 728 data input and NICAM sound subcarrier operating modes. The input interface also monitors the input sync pulse.

For the digital TV standards, the input interface is equipped with four ASI inputs (DVB-T/-H) or two SMPTE 310M and two ASI inputs (ATSC). This makes it a universal input stage – capable of handling all operating modes of the DVB-T/-H and ATSC standards.



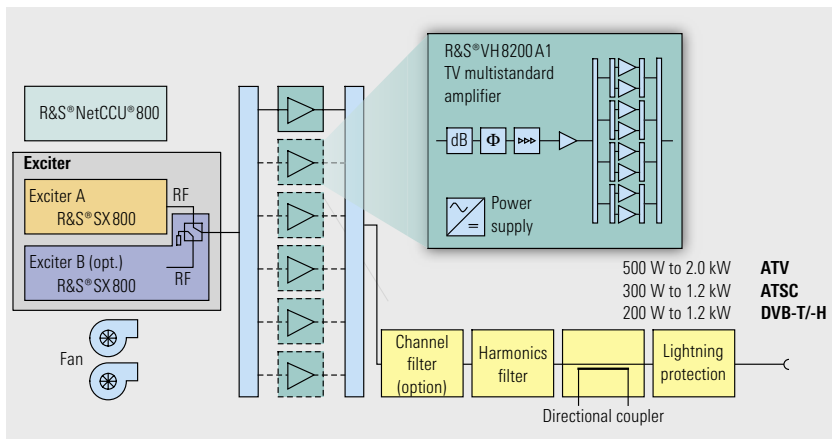

Block diagram of an R&S® Nx8200 TV transmitter

For digital applications, the input interface monitors the packet synchronization and the data rate of the input signals. Input data buffers eliminate line-side jitter and wander effects.

For operation in single-frequency networks (SFN), an MIP decoder in line with TS 101191 is included in the signal processing. The decoder enables automatic delay compensation and automatic operating mode detection.

Seamless, automatic input signal switching ensures a redundant signal feed.

The exciter can be converted from analog to digital at any time, involving only a minimum of effort.

Mainboard

The mainboard digitally processes and modulates the signals from the input interface in line with the corresponding TV standard. Digital signal processing ensures maximum stability and allows easy precorrection.

The signals undergo modulation, applying the appropriate algorithm for analog or digital TV. The resulting digital in-phase and quadrature (I and Q) signals are taken to a precorrector. Linear precorrection compensates for group delay and frequency response, which occur in power filters in the RF path, for example. Nonlinear precorrection corrects distortion products generated in the amplifiers.

The digital precorrection implemented here ensures 100% reproducibility. For the digital standards, automatic/adaptive precorrection is available as an option.

RF interface

The RF interface first converts the digital I and Q signals to analog baseband signals. These are double-converted in a subsequent modulator section to yield the final modulated signal.

A synthesizer supplies the frequencies required for upconversion. It can of course be locked to an external

reference frequency. The high-quality reference oscillator ensures that the required frequency accuracy for SFNs is maintained even if the external reference fails.

The RF interface can optionally be equipped with a demodulator path that processes the amplified and/or filtered RF signal so that it can be analyzed for automatic/adaptive precorrection. For this option, the exciter is equipped with two inputs that allow the signal to be tapped ahead of and after the power filter without external switches being required.

Overview of the special characteristics of the TV Exciter R&S® Sx800:

General

- ◆ Integrated digital linear and nonlinear precorrection
- ◆ Digital signal processing for analog and digital TV

Digital TV

- ◆ DVB-T/-H, ATSC
- ◆ All ASI modes
- ◆ SMPT310M
- ◆ Suitable for single-frequency networks (SFN) and multifrequency networks (MFN)
- ◆ Hierarchical modulation (DVB-T/-H)
- ◆ Seamless input switching
- ◆ MIP monitoring
- ◆ Automatic/adaptive precorrection (optional)

Analog TV

- ◆ Standards B/G, D/K, M/N, I
- ◆ PAL, SECAM and NTSC
- ◆ FM mono, dual-sound/stereo IRT or, optionally, NICAM

Power amplifier

The air-cooled broadband R&S®VH 8200 A1 amplifier operates in the range from 470 MHz to 862 MHz (UHF bands IV/V). It can be used both for analog and digital signals without requiring any adjustments, which means a smaller inventory of spare parts for operators of mixed transmitter networks.

The output power of each amplifier plug-in depends on the modulation mode: 200 W for DVB-T/H, 300 W for ATSC and 500 W for analog TV (combined). Due to the use of advanced LDMOS technology, the power amplifiers offer very high linearity, excellent efficiency and compact design. Each amplifier plug-in contains a predriver and a driver stage, eight power transistors and a separate power supply.

An innovative amplifier controller is used, which is identical for all sound and TV transmitters of the Rohde & Schwarz Nx8000 family. This controller not only monitors and evaluates protective functions (e.g. overtemperature switchoff, VSWR reduction, transistor failure detection), but also provides phase correction and control of the RF output power. Output power control prevents, for example, the amplifier from being overdriven in the event a transistor fails, thus ensuring a long life for the individual transistors. Each amplifier module is, therefore, self-monitoring and self-protecting.

All relevant operating parameters and fault messages are transferred to the transmitter control unit via the CAN bus interface, which is likewise an innovative feature. The amplifier modules can easily be replaced during operation.

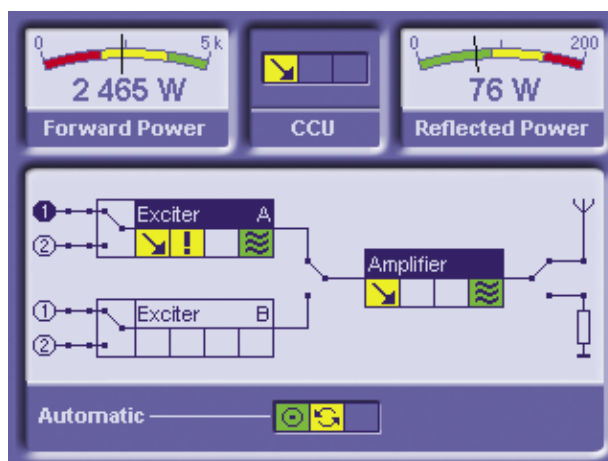

Main menu of the R&S® NetCCU® 800

Control Unit R&S®NetCCU®800

The innovative R&S®NetCCU® 800 transmitter control unit handles both internal and external communication and provides all control functions. Only two height units suffice to implement the functions of a transmitter control unit plus an IP interface. The R&S®NetCCU® 800 clearly shows the current status of the transmitter system on a color display.

All transmitter and/or amplifier parameters required for diagnostics can be retrieved locally as well as remotely from anywhere in the world via a standard (IP) protocol and standard software (Web browser, SNMP). This enables the transmitter status of unattended stations to be accurately evaluated, and any servicing that may be needed to be optimally prepared. Locally, this data can be retrieved via the IP interface of the R&S®NetCCU® 800.

Transmitter rack with integrated cooling

A 19" rack (depth 800 mm) is used for all power classes. One rack accommodates up to six amplifier modules. The rack contains two built-in fans that operate in active standby.

Various air ducting configurations can be implemented, with cooling air intake from the top, bottom or rear of the transmitter rack, and exhaust air discharge toward the top or bottom. Each amplifier module contains an optimized, highly efficient heat sink. This in conjunction with the elaborate cooling concept ensures effective cooling with only small amounts of air. This in turn considerably reduces the cooling system's power consumption and noise generation.

An innovative, nearly wireless power distribution system eliminates wiring errors during assembly.

A channel filter integrated in the transmitter (for analog operation), a frequency-response-compensated directional coupler and built-in lightning protection round out the R&S®NH/NV 8200 family of transmitters.

Specifications

Specifications common to R&S®NH/NV 8200

Frequency range	470 MHz to 862 MHz
Power supply	3 × 400 V AC ±15%, three-phase operation; 47 Hz to 63 Hz
Max. installation altitude	2000 m above sea level (>2000 m on request)
Operating temperature range	+1 °C to +45 °C
Permissible relative humidity	95%, without condensation
Dimensions (W × H × D)	600 mm × 2000 mm × 800 mm
RF connector	1 ⁵ / ₈ EIA
Synchronization	
Reference frequency	10 MHz, 0.1 V to 5 V (pp) or TTL, BNC
Reference pulse	1 Hz, TTL, BNC
Local and remote control	
Local control	
Color display and keys	front-panel operation via graphical user interface (GUI)
RJ-45	PC operation via standard Web browser
Remote control	
RJ-45	IEC 864-2 via Ethernet, standard
RJ-45	network management interface (Web server and/or SNMP agent), optional
Parallel interface	floating contacts for messages and commands, optional
Bit bus	bus interface, meets IEC 864-2, optional

Specifications of R&S®NH 8200 for analog TV

	R&S® NH 8201	R&S® NH 8202	R&S® NH 8203	R&S® NH 8204
Number of amplifiers	1	2	3	4
RF output power	500 W	1 kW	1.5 kW	2 kW
Rate of air flow	8.5 m ³ /min		17 m ³ /min	
Reference frequency	10 MHz, 0.1 V to 5 V (pp) or TTL, BNC			
TV standards	B, G, D, K, M, N, I			
Color transmission	PAL, NTSC, SECAM			
Inputs (video)	2 × video			
Inputs (audio)	without Nicam: 2 × AF with Nicam: 2 × AF + 1 × AF for third language standard M/N: 1 × AF + 1 × BTSC (BNC)			
Sound transmission	dual-sound coding to IRT, FM single-sound and NICAM 728 (–13 dB/–20 dB) (optional); FM single-sound (–10 dB), BTSC coder input			

Specifications of R&S®NV 8200 for DVB-T/-H (meets EN 300744/EN 302304)

	R&S® NV 8201	R&S® NV 8202	R&S® NV 8203	R&S® NV 8204	R&S® NV 8205	R&S® NV 8206
Number of amplifiers	1	2	3	4	5	6
RF output power	200 W	400 W	600 W	800 W	1000 W	1200 W
Rate of air flow	8.5 m ³ /min			17 m ³ /min		
Inputs (DVB-T/-H)	4 × ASI					
Coding and modulation	meets EN 300744, EN 302304 (optional)					
Modulation	QPSK, 16QAM or 64QAM					
Guard interval	1/4, 1/8, 1/16 or 1/32 of useful symbol duration					
IFFT mode	2 k and 8 k, 4 k (optional)					
Inner code rate	1/2, 2/3, 3/4, 5/6 or 7/8					
Useful symbol duration	224 μs (2 k) or 896 μs (8 k), 448 μs (4 k, optional)					

Specifications of R&S®NV8200 for ATSC (meets Doc. 53/1995)

	R&S®NV8201	R&S®NV8202	R&S®NV8203	R&S®NV8204
Number of amplifiers	1	2	3	4
RF output power	300 W	600 W	900 W	1200 W
Rate of air flow	8.5 m³/min		17 m³/min	
Inputs (ATSC)	2 × SMPTE + 2 × ASI			
Modulation	8VSB			
Symbol rate	10.76 MHz			
Data rate	19.39 Mbit/s			
Trellis coding	2/3			
Reed-Solomon encoding	207/187/10			

More information at
www.rohde-schwarz.com
 (search term: NH8200, NV8200)



www.rohde-schwarz.com

Europe: +49 1805 12 4242, customersupport@rohde-schwarz.com
 Americas: +1-888-837-8772, customer.support@rsa.rohde-schwarz.com
 Asia: +65 65 130488, customersupport.asia@rohde-schwarz.com